



PS-6V210

6 Volt 210 AH @ 20-hr. rate

Rechargeable Sealed Lead Acid Battery
Designed for Cyclic, Standby, and Solar Applications



Terminals - SAE Studs (Pos: 19.5mm, Neg:17.9mm)

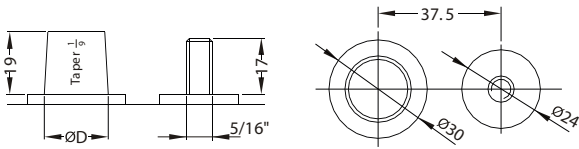

Physical Dimensions: in (mm)

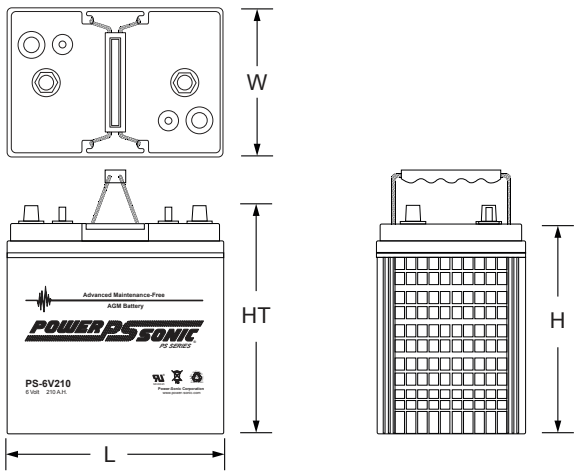

L: 10.24 (260) W: 7.09 (180) H: 9.92 (252) HT: 10.79 (274)

Tolerances are +/- 0.04 in. (+/- 1mm) and +/- 0.08 in. (+/- 2mm) for height dimensions. All data subject to change without notice.

Features

- **Maintenance-Free, Non-Spillable** - Proven VRLA technology guarantees safe operation without maintenance and 'nonrestricted article' status for air, land or water transportation.
- **Charging** - Battery can be charged in any orientation/position (upside down not recommended)
- **Long Service Life** - High capacity design, excellent deep cycle property.
- **Low Internal Resistance** - High strength conductive terminals for high current discharging.
- **Designed-in Reliability** - Cutting-edge manufacturing and process control combined with meticulous quality assurance procedures guarantee consistent and dependable performance.

Performance Specifications

Nominal Voltage6 volts (3 cells)

Nominal Capacity

20-hr. (10.5A to 5.40 volts) 210 AH

5-hr. (37.0A to 5.25 volts) 185 AH

Approximate Weight 67 lbs. (30.4 kg)

Reserve Capacity (25 Amps) 475 min.

Reserve Capacity (75 Amps) 124 min.

Charge Methods (Constant voltage charging at 20 °C (68 °F))

Standby (Max. charge current: 0.25C_{10A}) 6.80-6.90V

Cyclic (Max. charge current: 0.25C_{10A}) 7.20-7.35V

Operating Temperature Range

Charge -14 °F (-10 °C) to 122 °F (50 °C)

Discharge -4 °F (-20 °C) to 140 °F (60 °C)

Case ABS Plastic

Cycle Life in Relation to Depth of Discharge

